

HZ763400TX

Chaz Cabinet

# Assembly Instructions

**HOLLY & MARTIN®**   
FUNCTION • MEETS • STYLE

Holly & Martin® a valued brand of SEI  
Customer Service: 1.800.633.5096  
[service@hollyandmartin.com](mailto:service@hollyandmartin.com)  
[www.hollyandmartin.com](http://www.hollyandmartin.com)

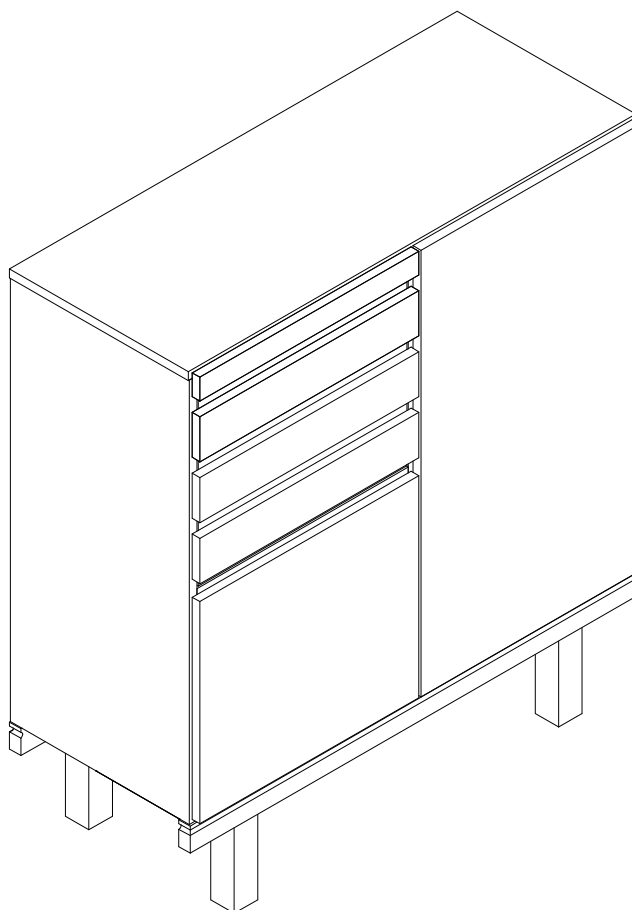

PO#:13584







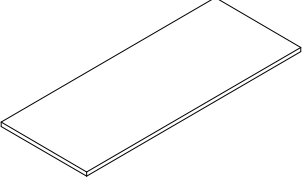
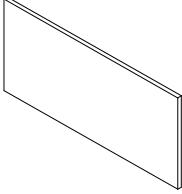
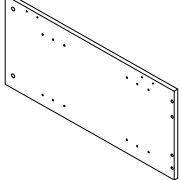
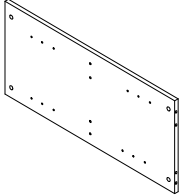
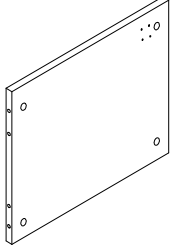
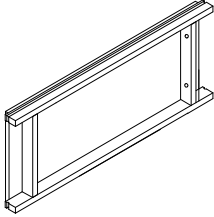
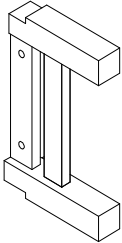
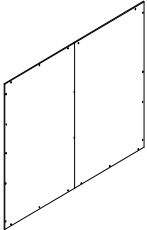
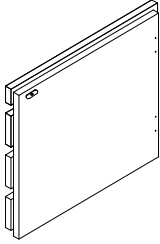
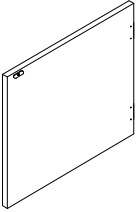

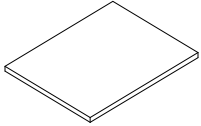



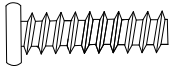

# Chaz Cabinet

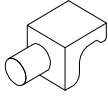
## Parts List

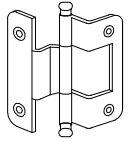
Please review all parts and hardware before disposing of any packaging. Before beginning assembly, separate each type of hardware. Carefully study the diagrams below and check that you have all parts indicated. Call Customer Service if missing hardware. Using the incorrect hardware will cause damage.

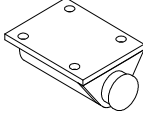
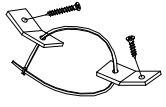
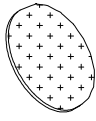
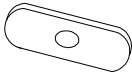
<b>1)</b>  Top Panel	Quantity of 1	<b>2)</b>  Left Side Panel	Quantity of 1	<b>3)</b>  Right Side Panel	Quantity of 1
<b>4)</b>  Middle Panel	Quantity of 1	<b>5)</b>  Shelf Panel	Quantity of 1	<b>6)</b>  Bottom Panel	Quantity of 1
<b>7)</b>  Leg Frames	Quantity of 2	<b>8)</b>  Back Panel	Quantity of 1	<b>9)</b>  Upper Left Door	Quantity of 1
<b>10)</b>  Lower Left Door	Quantity of 1	<b>11)</b>  Right Door	Quantity of 1	<b>12)</b>  Adjustable Shelf Panels	Quantity of 4

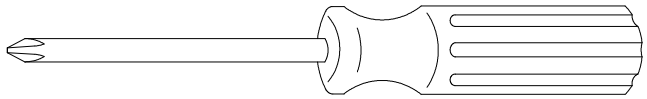
<p><b>A)</b> Quantity of 16</p>  <p>Cam Bolts</p>	<p><b>B)</b> Quantity of 16</p>  <p>Cam Locks</p>	<p><b>C)</b> Quantity of 16</p>  <p>Wood Dowels Dia. 5/16"x1-1/4"L</p>
<p><b>D)</b> Quantity of 4</p>  <p>Bolts Dia. 1/4"x1-3/4"L</p>	<p><b>E)</b> Quantity of 4</p>  <p>Spring Washers Dia. 1/4"</p>	<p><b>F)</b> Quantity of 4</p>  <p>Flat Washers Dia. 1/4"x3/4"</p>
<p><b>G)</b> Quantity of 1</p>  <p>Allen Wrench</p>	<p><b>H)</b> Quantity of 16</p>  <p>Shelf Pins</p>	<p><b>I)</b> Quantity of 24</p>  <p>Screws Dia. 1/8"x5/8"L</p>
<p><b>J)</b> Quantity of 6</p>  <p>Hinges</p>	<p><b>K)</b> Quantity of 36</p>  <p>Screws Dia. 1/8"x1/2"L</p>	<p><b>L)</b> Quantity of 3</p>  <p>Magnets</p>
<p><b>M)</b> Quantity of 2</p>  <p>Anti-Tipping Hardware</p>	<p><b>N)</b> Quantity of 8</p>  <p>Cotton Mats</p>	<p><b>O)</b> Quantity of 3</p>  <p>Magnet Plates</p>
<p><b>P)</b> Quantity of 3</p>  <p>Screws Dia. 1/8"x1/2"L</p>		
<p><b>Care and Cleaning Instructions:</b>          Before using, wipe with a clean, dry cloth. Periodically apply furniture wax to renew the finish. Avoid rubbing or scratching the surface with rough or abrasive objects.</p>		<p>For replacement parts or questions, please call Customer Service at 1-800-633-5096.</p>
<p><b>Assembly Tool Required:</b>          No.2 Phillips Screwdriver          (Not Included)</p>		

# Chaz Cabinet

## Assembly Instructions

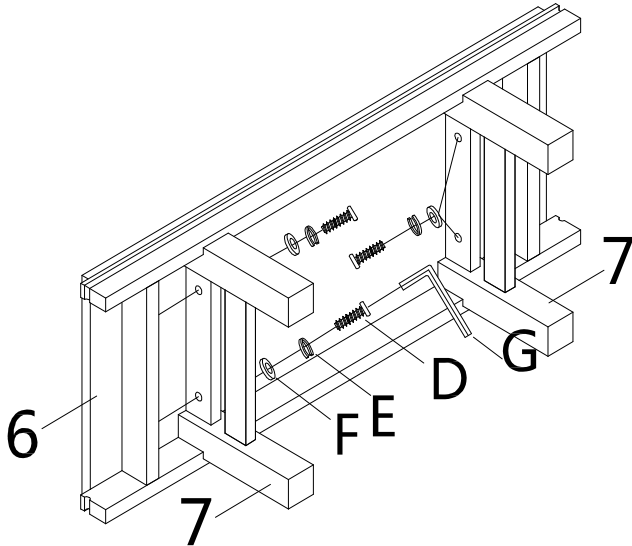
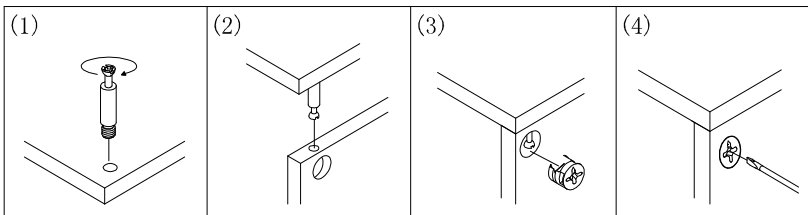

Figure 1

Start with fingers to help align bolts before using screwdriver.

Use Bolts (D), Flat Washers (F), and Spring Washers (E) to connect Bottom Panel (6) to Leg Frames (7).

Tighten bolts using Allen Wrench (G).



"Please do not over tighten cambolts. Please stop when you feel tight"

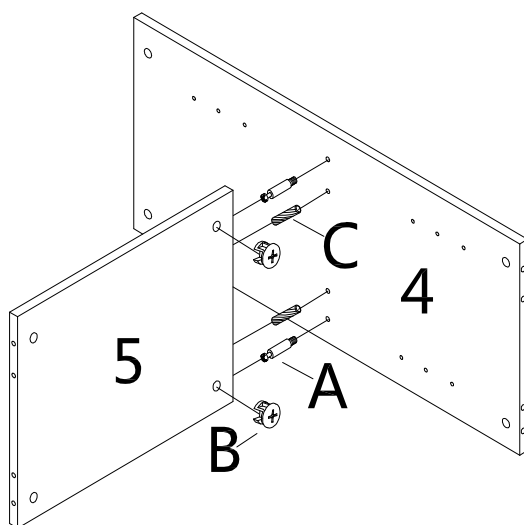

Figure 2

Start with fingers to help align cam bolts before using screwdriver.

Insert Cam Locks (B) into holes on Shelf Panel (5).

Screw Cam Bolts (A) into threaded holes on Middle Panel (4).

Attach Middle Panel (4) to Shelf Panel (5) using Cam Bolts (A) and Wood Dowels (C).

Tighten by rotating Cam Locks (B) clockwise with Phillips screwdriver.

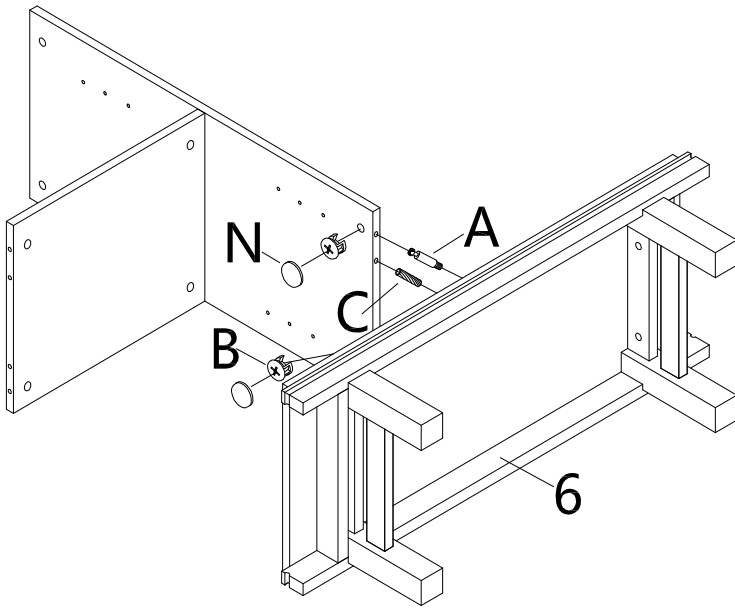

Insert Cam Locks **(B)** into holes on Middle Panel **(4)**.

Screw Cam Bolts **(A)** into threaded holes on Bottom Panel **(6)**.

Attach Bottom Panel **(6)** to Middle Panel **(4)** using Cam Bolts **(A)** and Wood Dowels **(C)**.

Tighten by rotating Cam Locks **(B)** clockwise with Phillips screwdriver.

Cover Cam Locks **(B)** with Cotton Mats **(N)**.

**Figure 3**

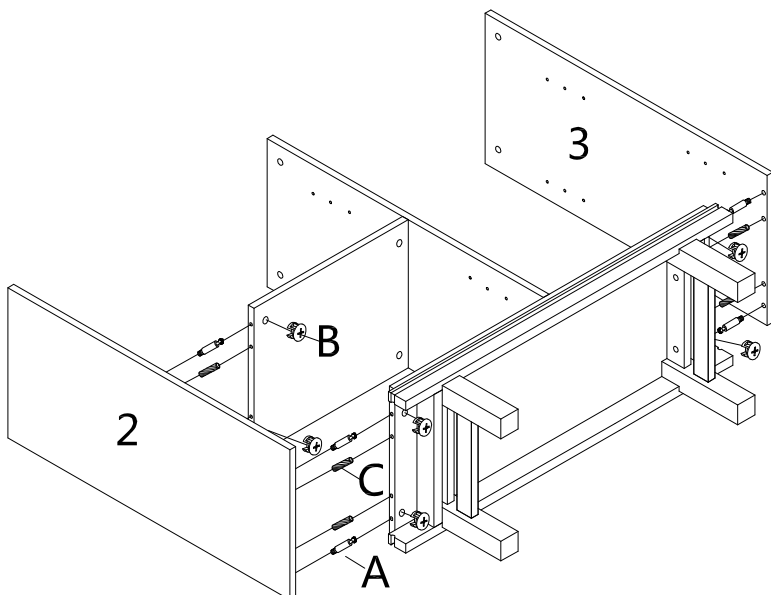

Insert Cam Locks **(B)** into holes on assembled unit from **Figure 3**.

Screw Cam Bolts **(A)** into threaded holes on Left Side Panel **(2)** and Right Side Panel **(3)**.

Attach Left Side Panel **(2)** and Right Side Panel **(3)** to assembled unit using Cam Bolts **(A)** and Wood Dowels **(C)**.

Tighten by rotating Cam Locks **(B)** clockwise with Phillips screwdriver.

**Figure 4**

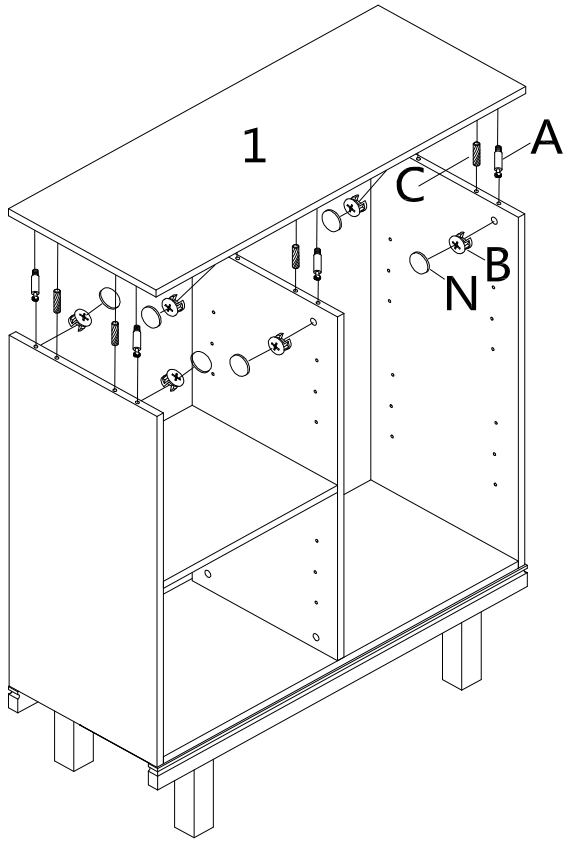

**Figure 5**

Insert Cam Locks **(B)** into holes on assembled unit from **Figure 4**.

Screw Cam Bolts **(A)** into threaded holes on Top Panel **(1)**.

Attach Top Panel **(1)** to assembled unit using Cam Bolts **(A)** and Wood Dowels **(C)**.

Tighten by rotating Cam Locks **(B)** clockwise with Phillips screwdriver.

Cover Cam Locks **(B)** with Cotton Mats **(N)**.

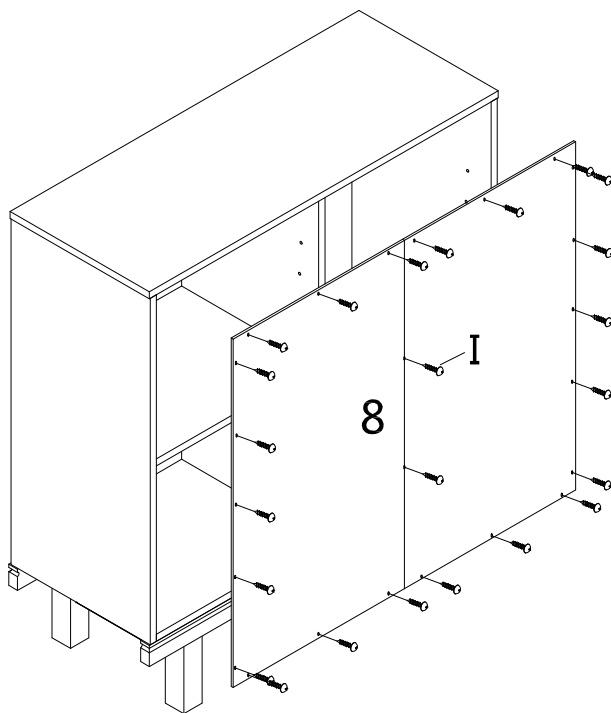

**Figure 6**

Attach Back Panel **(8)** to unit with Screws **(I)**.

Tighten screws with Phillips screwdriver.

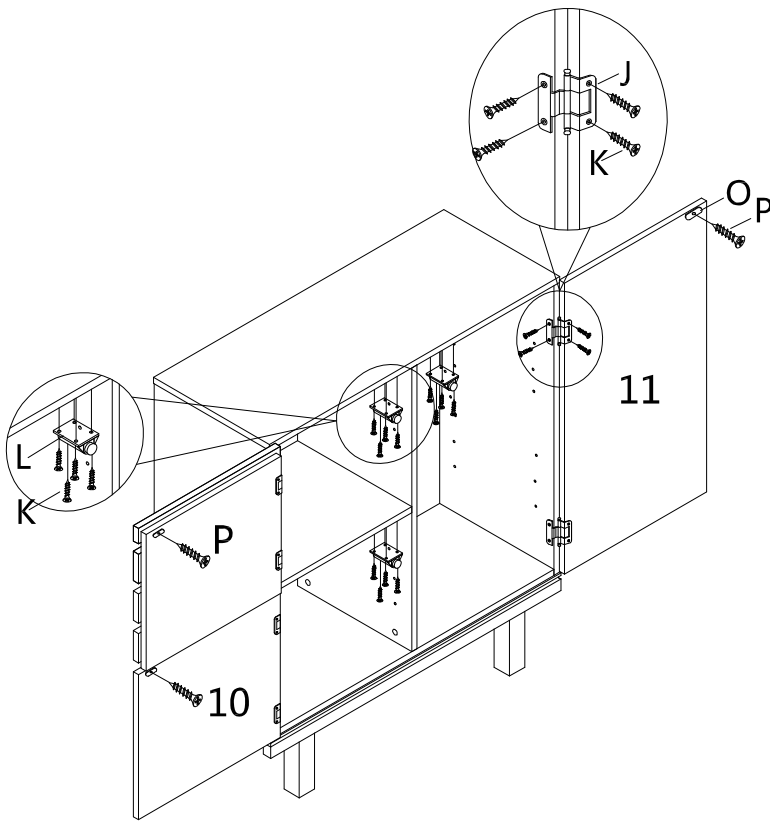

**Figure 7**

Attach Hinges (**J**) to side panels and doors with Screws (**K**).

Tighten screws with Phillips screwdriver.

Attach Magnet Plates (**O**) to doors with Screws (**P**).

Attach Magnets (**L**) to unit from **Figure 6**.

Tighten screws with Phillips screwdriver.

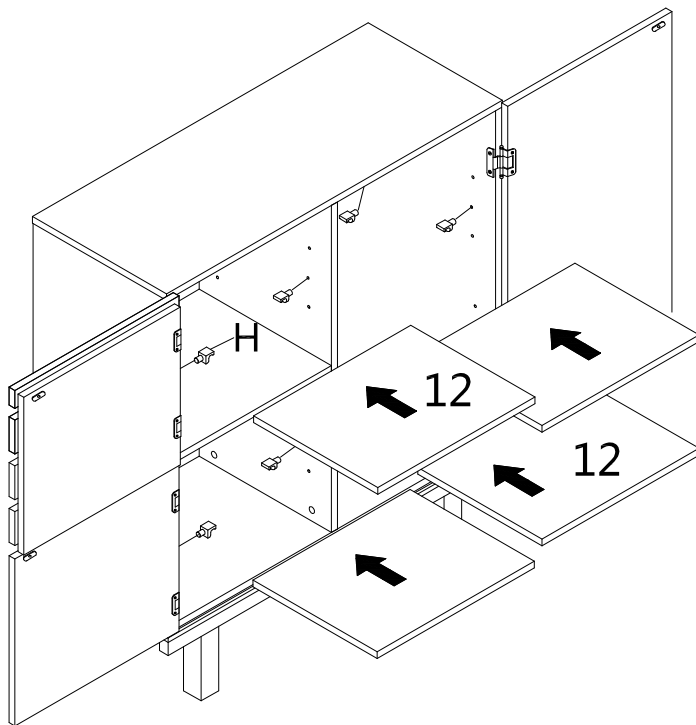

**Figure 8**

Insert Shelf Pins (**H**) into predrilled holes on inside of unit.

Insert Adjustable Shelf Panels (**12**) in direction of arrows. Make sure shelf pins stably hold adjustable shelf panels.

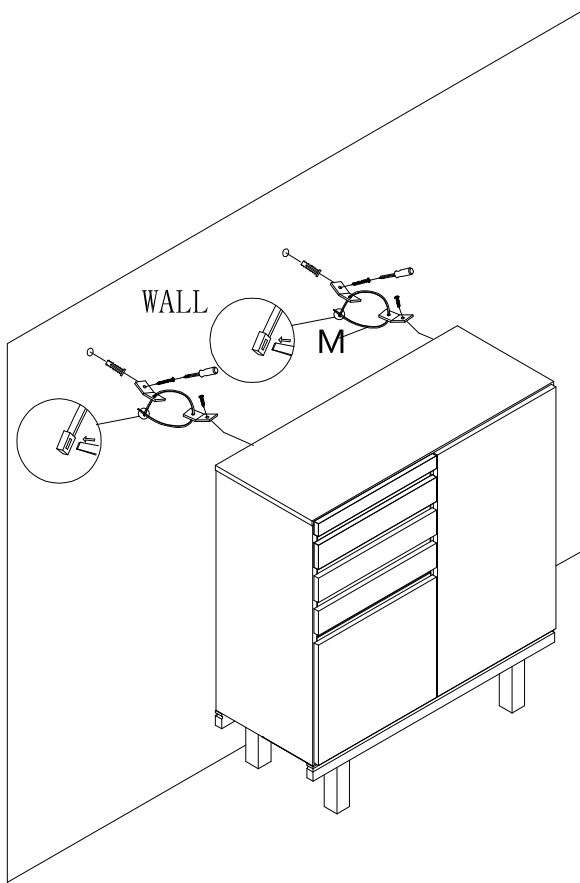

Figure 9

Attach Brackets **(M)** to Back Panel using Screws **(M)**. Tighten screws with Phillips screwdriver.

Mark two desired locations on wall, same distance as Brackets **(M)** on back of unit. Drill two 3/16" holes. Insert Plastic Anchors **(M)** into holes on wall. **(Use a hammer to help you).**

Attach Brackets **(M)** to wall using Screws **(M)**. Tighten screws with Phillips screwdriver.

Move this item close to wall Brackets **(M)** and tie in both Brackets **(M)** with Plastic Straps **(M)** as shown.

**Anti-tipping hardware must be used for this product to avoid tipping and injury.**

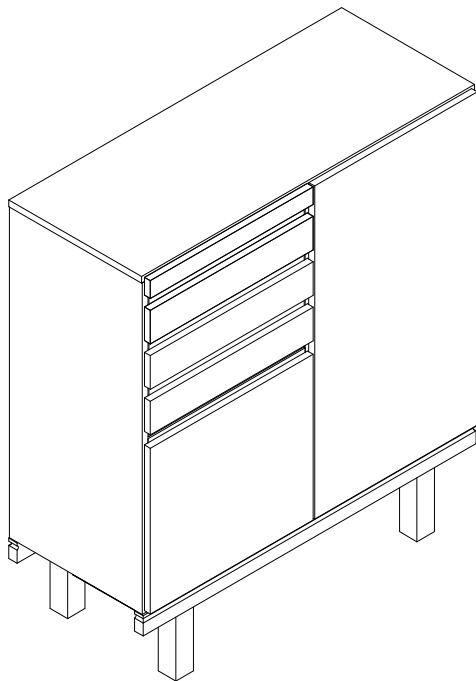

Figure 10

Now your Chaz Cabinet is ready to use!



# Parts Replacement Form

## Customer Information

Name \_\_\_\_\_

Address \_\_\_\_\_

City/State/Zip Code \_\_\_\_\_

Phone Number \_\_\_\_\_

Please indicate where you purchased this item: Store/Website/Catalog

\_\_\_\_\_

Please indicate color/size/style number:

\_\_\_\_\_

Style No	Parts Letter	Parts Description	Quantity Needed
_____	_____	_____	_____
_____	_____	_____	_____
_____	_____	_____	_____

Please immediately examine this product carefully. Any request for missing parts or damage replacement must be received within 90 days of your receipt of the product. Replacement, if available, will be honored within this time frame. Parts will not be available for items arriving fully assembled. We do not recommend modifying product(s) and we are not responsible for any damages due to product modification(s). If damages or missing parts are not reported within 90 days of your receipt, we are under no obligation to provide parts or replacement merchandise.

For product issues, please contact Southern Enterprises at 800-633-5096 (toll-free) / 972-869-0111 (Dallas), Mon-Fri 9am – 4pm CST, or email us at [service@seidal.com](mailto:service@seidal.com). Please ask for customer service representative for issues involving damages or replacement parts. Please ask for technical assistance representative for any issues with product and assembly/construction.

Please contact the retailer that you purchased from for returns.



Customer Service: 1.800.633.5096  
[service@hollyandmartin.com](mailto:service@hollyandmartin.com)  
[www.hollyandmartin.com](http://www.hollyandmartin.com)

600 Freeport Parkway, Suite 200  
Coppell, Texas 75019