

CK792000TX - Bannock 2pc Table Set-

Gray Matte

CK793000TX - Bannock 2pc Table Set -

Dark Tobacco



Holly & Martin® a valued brand of SEI

Customer Service [1-800-633-5096](tel:1-800-633-5096)

service@hollyandmartin.com

www.hollyandmartin.com

ASSEMBLY INSTRUCTIONS

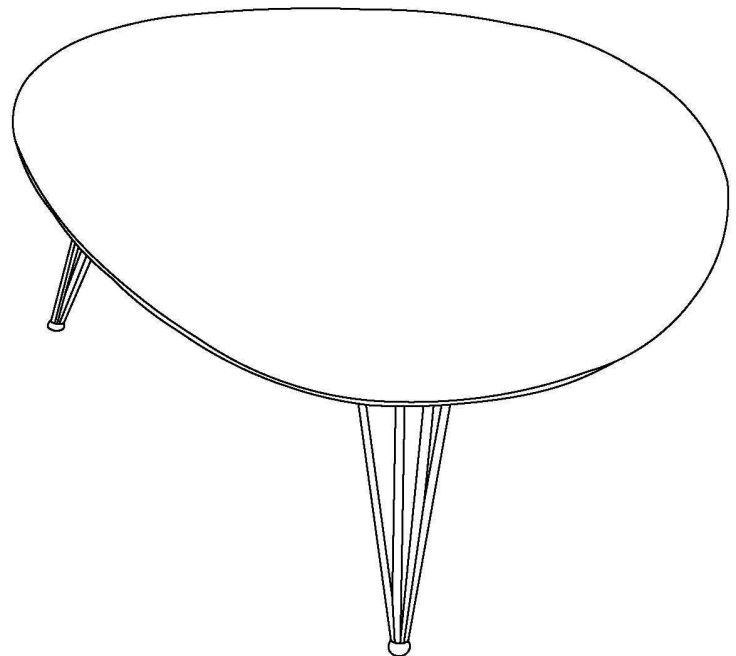

PO#:13924



Bannock 2pc Table Set

Parts List

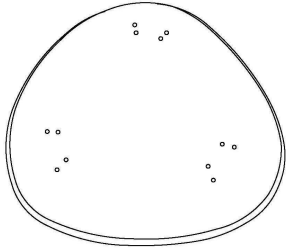
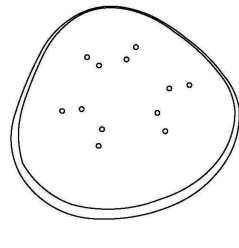
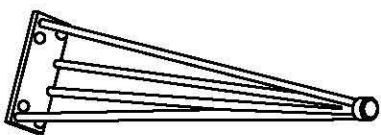
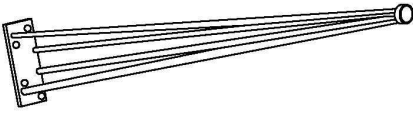
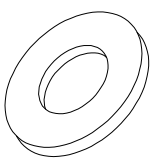
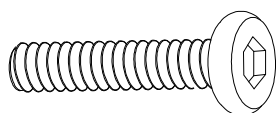
Please check packaging for all parts and hardware before discarding. Unpack and lay parts on clean, padded surface like carpet or blanket. Check that you have all parts indicated. Call customer service if hardware is missing. Before beginning assembly, carefully study the diagrams below and sort your hardware according to the pictures. Using the incorrect hardware will cause damage.

<p>A</p>  <p>large top</p>	<p>B</p>  <p>small top</p>
<p>C</p>  <p>large table leg</p>	<p>D</p>  <p>small table leg</p>
<p>1</p>  <p>flat washer</p>	<p>2</p>  <p>bolt (Dia5/16"x 5/8"L)</p>
<p>3</p>  <p>allen wrench</p>	
<p>Care and Cleaning Instructions: Before using, wipe with a clean, dry cloth. Periodically apply furniture wax to renew the finish. Avoid rubbing or scratching the surface with rough or abrasive objects.</p>	<p>For replacement parts or questions, please call customer service at 1-800-633-5096.</p>

Bannock 2pc Table Set

Assembly Instructions

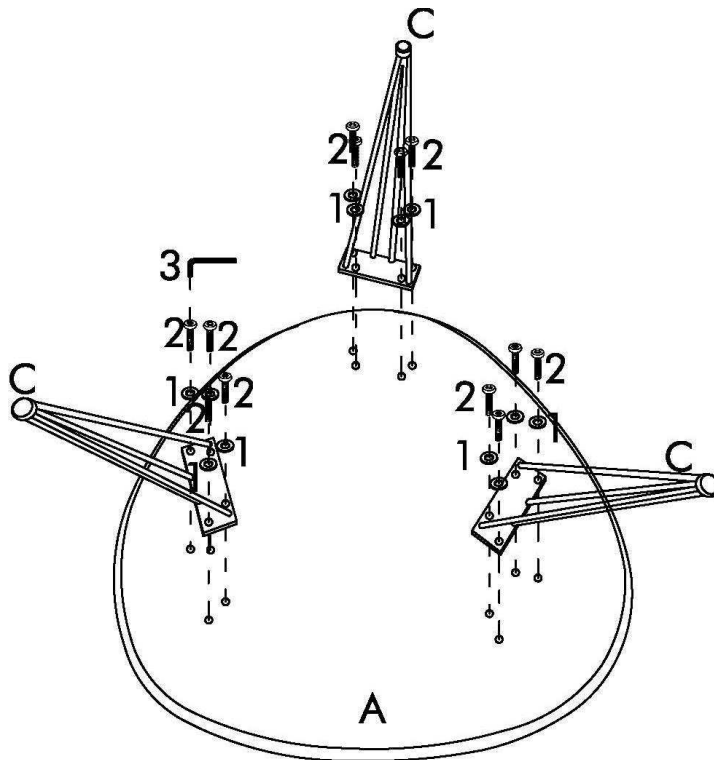

Figure 1

Attach large table legs (C) to large top (A) with bolts (2) and flat washers (1).

Tighten bolts with allen wrench (3).

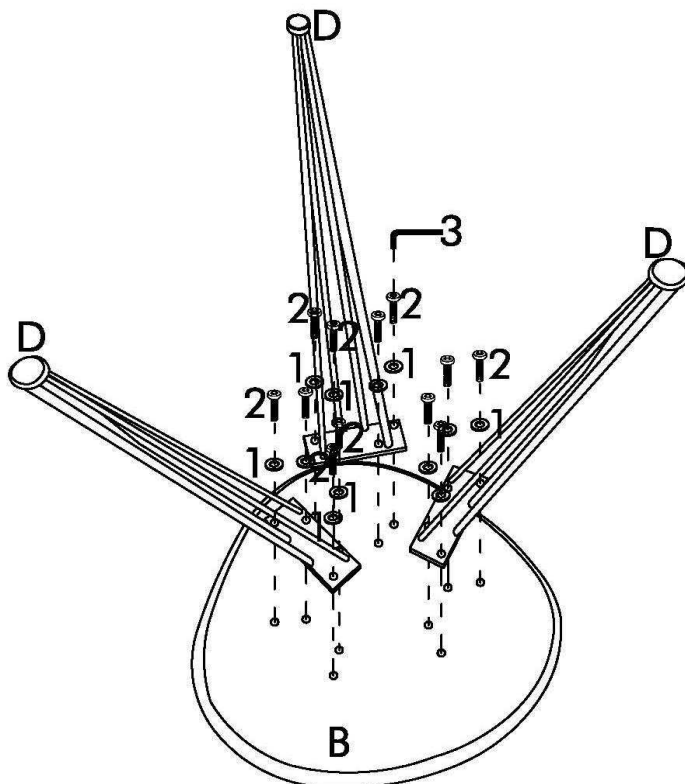

Figure 2

Attach small table legs (D) to small top (B) with bolts (2) and flat washers (1).

Tighten bolts with allen wrench (3).

Bannock 2pc Table Set

Assembly Instructions

Now your new Bannock 2pc table set is ready to use.

LARGE TABLE SUPPORTS UP TO 30 LB.

SMALL TABLE SUPPORTS UP TO 20 LB.



Figure 3

Parts Replacement Form

Customer Information

Name _____

Address _____

City/State/Zip Code _____

Phone Number _____

Please indicate where you purchased this item: Store/Website/Catalog

Please indicate color/size/style number:

Style No	Parts Letter	Parts Description	Quantity Needed
_____	_____	_____	_____
_____	_____	_____	_____
_____	_____	_____	_____

Please immediately examine this product carefully. Any request for missing parts or damage replacement must be received within 90 days of your receipt of the product. Replacement, if available, will be honored within this time frame. Parts will not be available for items arriving fully assembled. We do not recommend modifying product(s) and we are not responsible for any damages due to product modification(s). If damages or missing parts are not reported within 90 days of your receipt, we are under no obligation to provide parts or replacement merchandise. Please contact Southern Enterprises at 800-633-5096 or in Dallas 972-869-0111/ 9am – 4pm Mon-Fri Central time if you have product issues or email us at service@seidal.com. Please ask for customer service representative for issues involving damages or replacement parts. Please ask for technical assistance representative for any issues with product and assembly/construction.

Please contact the retailer that you purchased from for returns.



Customer Service [1-800-633-5096](tel:1-800-633-5096)
service@hollyandmartin.com
www.hollyandmartin.com
600 Freeport Parkway, Suite 200
Coppell, Texas 75019